

## Technical Whitepaper

# BB5 launch complements CPC Pumps International API 610 range

### Introduction

Already well known for its wide range of niche pumps, the Canada-headquartered CPC Pumps International has extended its product range by launching its first-ever BB5 pump.

In keeping with the design ethos that has served the company well for so many decades, each of its BB5 pumps is individually tailored to meet the specific requirements of every customer.



### Full product range

CPC Pumps International already has a range of models available, ranging from its OH2 to OH5, VS1, VS4, VS6, BB2, and BB3 models. With the launch of its latest between-bearings pump, the BB5, it has now a full complement in the heavy-duty process pumps range. The development of the BB5 opens opportunities in the more extreme high-pressure side of the business.

Effectively, the BB5 is either a BB3 (volute) or a BB4 (diffuser) type of pump inserted inside a radially split secondary casing (known as a “barrel” due to its barrel-like shape). It is precisely this double-casing design, combined with improved sealing designs, that allows the BB5 to be employed with higher temperatures, higher pressures, and low SG fluids.

---

#### CPC Pumps International Inc.

Part of the Atlas Copco Gas and Process Division

5200 Mainway, Burlington, ON, Canada L7L 5Z1

Phone: +1 (289) 288-4753

Email: [info@cpcpumpc.com](mailto:info@cpcpumpc.com)

[www.cpcpumps.com](http://www.cpcpumps.com)

## **API compliant**

CPC's BB5 is fully compliant with API 610 requirements (the standard for centrifugal pumps for petroleum, petrochemical and natural gas industries), which lays out in detail which pumps should be used in which process situations and conditions. API 610 outlines that pumps with radially split casings should be employed in the following operating conditions:

- pumping temperatures of 200 °C or higher
- liquids with a relative density of 0.7 at the specified pumping temperature
- liquids at a rated discharge gauge pressure above 10 MPa

Despite the API 610 standard, for various reasons, including cost, some plants have employed other pumps on processes with higher temperatures or pressures, when technically a BB5 would be a better fit (such as with condensed ethylene, liquified natural gas and supercritical CO<sub>2</sub>). An example is that some plants employ a BB3 for fluid below 0.7 SG density when API 610 calls for a BB5.

## **Parameters and features**

Though CPC Pumps International is obviously not the first pump specialist to develop a BB5 pump, there are a number of design features that make its creation distinct. Just as with every other pump in the company's product range, what sets its BB5 apart is the company's long history of producing customized pumps that match the precise needs of each customer.

As part of the design process, engineers tailor to the hydraulic needs of each application and customer, thereby, providing each pump with wide-ranging hydraulic coverage. The diffuser design can allow for individually unique stages in the pump to support very specialized applications, such as compressible fluids where flow rates within the pump are impacted by the local pressure of each stage. There is also the ability to future-proof the pump by changing out stages at a later date (if the process conditions change) in a cheaper and more effective way than the BB3 volute pump can handle.

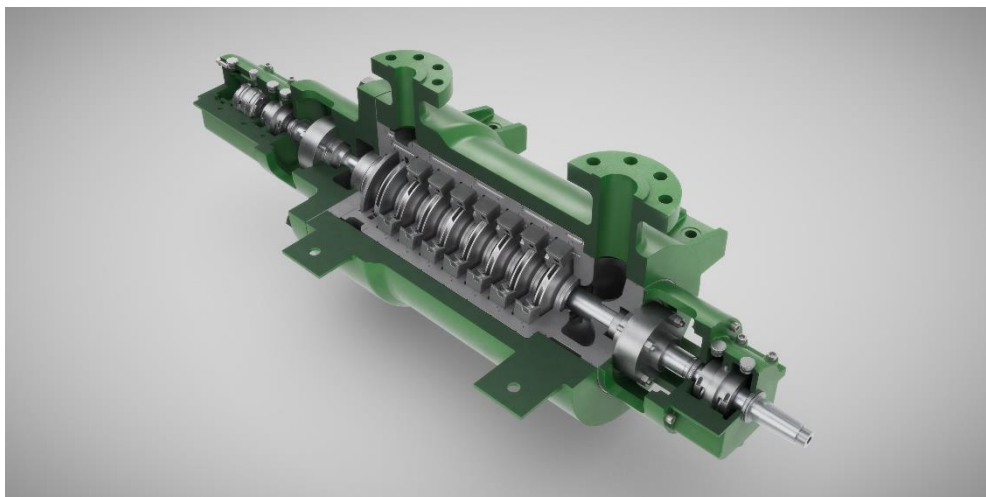

The BB5 operates with a flow rate above 4,400 USGPM (1,000 m<sup>3</sup>/h) and head beyond 12,000 feet (3,660 meters). It can handle temperatures up to 450 °C and it has a standard design working pressure of 15,000 kpag. In addition to its wide hydraulic coverage and tailored hydraulic selections, standard features also include diffuser and volute designs, balancing drum or hydraulically opposed impeller arrangement for thrust balancing, integral balance line for minimized chamber pressures, and a heavy baseplate, drip rim or drip pan designs.

There are also optional features, such as alternative flange sealings, high-pressure special casing design, fan/heating-sink bearing housing cooling arrangements, and magnetic bearing housing isolators.

### **Part of the Atlas Copco Group**

Now part of the Atlas Copco Group since an August 2021 acquisition, CPC Pumps International has long been renowned, particularly across North America, for its customized overhung, between bearings and vertical suspended range of pumps. Flexibility to design to the needs of each customer's requirements has been at the core of its reputation for niche designs.

Becoming part of the Atlas Copco Group has also enabled both companies to share technical knowledge from a compressor-pump (and vice versa) perspective. For example, Atlas Copco Gas and Process has more than 15 years of experience in CO<sub>2</sub>/CCUS, and this can be passed on to CPC colleagues working in this field.

CPC Pumps International is known for its high-quality aftermarket services throughout the lifecycle of a purchased pump, something that has been further strengthened since joining Atlas Copco. Ownership

experience, therefore, does not end with the purchase of new equipment: Once commissioned, CPC is on hand for the service and maintenance of equipment throughout its entire lifecycle.

This entails providing routine inspections and preventive maintenance to make sure that the machinery is running optimally; factory-supported diagnostic assistance and advice; and in-house CPC Pumps International replacement parts based on the pump's unique engineering drawings. It also includes maintaining capital spares storage and carrying out emergency repairs.

## Applications

Applications for CPC centrifugal pumps have traditionally been in the wider refining and petrochemical industries. They can range from boiler feed water, cryogenic duties, seawater injection and gas plants to pipelines, amine, energy recovery and LNG.

Pumps for such applications can contribute to improving energy efficiency and enhance current operations. But the addition of the BB5 is particularly timely, primarily because one of its major applications will be in helping to sustainably lower environmental impacts. It will be used in carbon capture, utilization and storage (CCUS), processes that are central to lowering CO<sub>2</sub> emissions.



The removal of CO<sub>2</sub> from exhaust sources lowers greenhouse gas production and at the same time it can also harness CO<sub>2</sub> for various hydrocarbon processes. CCUS can, therefore, play a vital role in reducing emissions and in the transition to net zero targets. The BB5 also has the potential to be employed as a midstream pump in amine services to remove CO<sub>2</sub>.



Part of the **Atlas Copco** Gas and Process Division

Additionally, the BB5 could be employed to boost sCO<sub>2</sub> pressure for pipeline transport when sequestration location is some distance from the capture location. Alternatively, it could be employed to boost pressure at an injection site, something most CCUS projects have not usually required because the injection site and capture site were close together.

Moreover, as renewable energy utilization increases worldwide, the need for reliable pumps with the ability to handle extreme temperatures and pressures is critical. CPC's advanced hydraulic solutions can be tailored to support hydrogen, geothermal power, and flexible energy storage.

CPC Pumps International already has experience designing pumps for compressible fluids, giving it a head start on the expanding supercritical CO<sub>2</sub> market, a field in which accurate calculations are of the utmost importance. CPC engineers designed the HB pump range using CFD software in order to analyze challenges related to compressible fluids, which is another area in which the BB5 also has the potential to be employed.

## **Milestone**

The launch of the CPC Pumps International BB5 is another milestone for the company. Now supported by Atlas Copco, the BB5 means it can now offer a wider range of pumps to an increasingly geographically diverse international customer base. And as with all its other pump products, high-quality and customized design to match the requirements of each customer and application sets the BB5 apart.



Part of the Atlas Copco Gas and Process Division

**For further information please contact our media relations team:**

- Patrick Kessler – Global Communications & Digital Marketing Manager, Atlas Copco Gas and Process, +49 172 418 6680, [Patrick.kessler@atlascopco.com](mailto:Patrick.kessler@atlascopco.com)
- John Chittenden – Digital Marketing Specialist, CPC Pumps International +1 289 288 4778 [John.chittenden@cpcpumps.com](mailto:John.chittenden@cpcpumps.com)

**About CPC Pumps International**

CPC Pumps International Inc. is a part of the Atlas Copco Group, a world-leading industrial group present in more than 180 countries, over the span of over 145 years. It is a company that serves customers with innovative compressor, vacuum, power, and industrial technologies.

CPC Pumps International Inc. carries a heritage that dates back to 1957. We have cultivated a long history of partnership and collaboration. Pairing that with constant innovation for pump solutions throughout our history, we have been able to consistently respond to change and add value for every customer that has been a part of our legacy.

**About Atlas Copco Gas and Process**

At Atlas Copco Gas and Process, we help customers prepare for tomorrow by designing, building, and servicing turbocompressors, gas screw compressors, turboexpanders, and API 610 centrifugal pumps for the hydrocarbon processing, power generation (both conventional and renewable) and industrial gases industries. Our passionate people are dedicated to helping customers handle today's pressures while creating a sustainable future.